

## EDM-G-IMX8M-MINI

- Modern System on Module form factor
- Up to 4 Cortex-A53 1.8 GHz processors
- NXP i.MX 8M Mini applications processor
- Armv8 64-Bit CPU cor

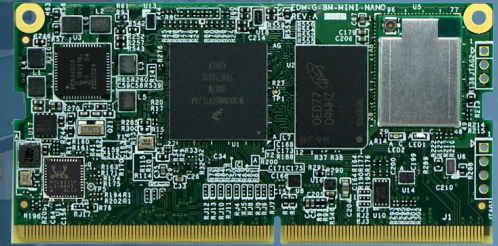

### Core System

Processor	NXP i.MX8M Mini
Architecture	ARM Cortex-A53 + M4
AI / ML	OpenCL CPU: 32 GOPS
PMIC	NXP PCA9450
Memory	Up to 8GB LPDDR4
Storage	32GB eMMC (default)
Board-to-Board Connector	260-pin DDR4 SO-DIMM
System on Module	EDM SOM
Debug Interface	JTAG Interface by Through-hole

### Signaling

I/O	LVDS LAN MIPI CSI MIPI DSI PCIe USB USB OTG I <sup>2</sup> S SDIO UART SPI I <sup>2</sup> C PWM GPIO
-----	---

### Connectivity

Network LAN	1x Realtek RTL8211
Wi-Fi	Qualcomm Atheros QCA9377 Wi-Fi 5 – 802.11 a/b/g/n/ac (optional)
Bluetooth	Qualcomm Atheros QCA9377 Bluetooth (optional)
Antenna	MHF4 connector (optional)

### Video

GPU Engine	GC NanoUltra (1 shader) GC520L (2D) OpenGL ES 2.0
Video decode	1080p60 (h.265, h.264, VP9, VP8)
Video encode	1080p60 (h.265, h.264)
Camera	Dual MIPI CSI (4 lanes)

## Audio

Audio Codec	On carrier board
Audio Connectors	I <sup>2</sup> S (2 channel)

## Power Specifications

Power Input	5V DC +/-5%
Power Consumption	Depending on Configuration

## Operation Systems

Standard Support	Linux Yocto Android Ubuntu
------------------	-------------------------------------

## Environmental and Mechanical

Dimensions	69.6 (W) x 35 (H) x 4.45 (D) mm
Form Factor	EDM Type G
Relative Humidity	10 to 90 %
MTBF	100,000+ Hours
Shock	15G half-sine 11 ms duration
Operation Temperature	Commercial: 0° to +60° C Industrial: -40° to +85° C
Vibration	1 Grms random 5-500Hz hr/axis
Weight	8 grams

## Certification and Compliance

USA	FCC ID: 2AKZA-QCA9377
Canada	IC: 22364-QCA9377
European Union	EN 300 328 v2.2.2 EN 301 893 v2.1.1 EN 55032 / EN 55024
Japan	TELEC: 201-180629
Australia/New Zealand	RCM Compliant
Bluetooth Logo	QDID 150839 (Bluetooth 4.2) QDID 193238 (Bluetooth 5)
Certification	Compliant with RoHS / REACH directives

## Dimensions (units in mm)

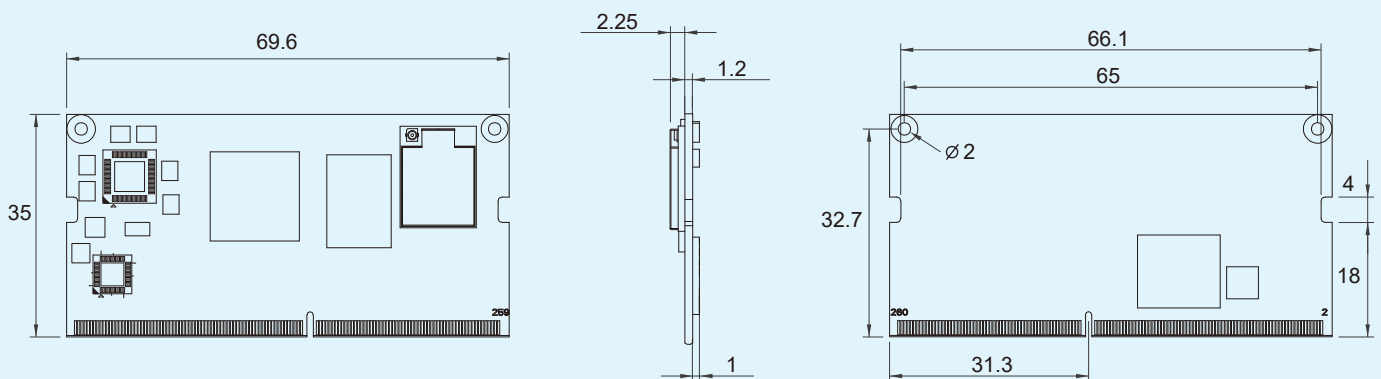

# Block Diagram

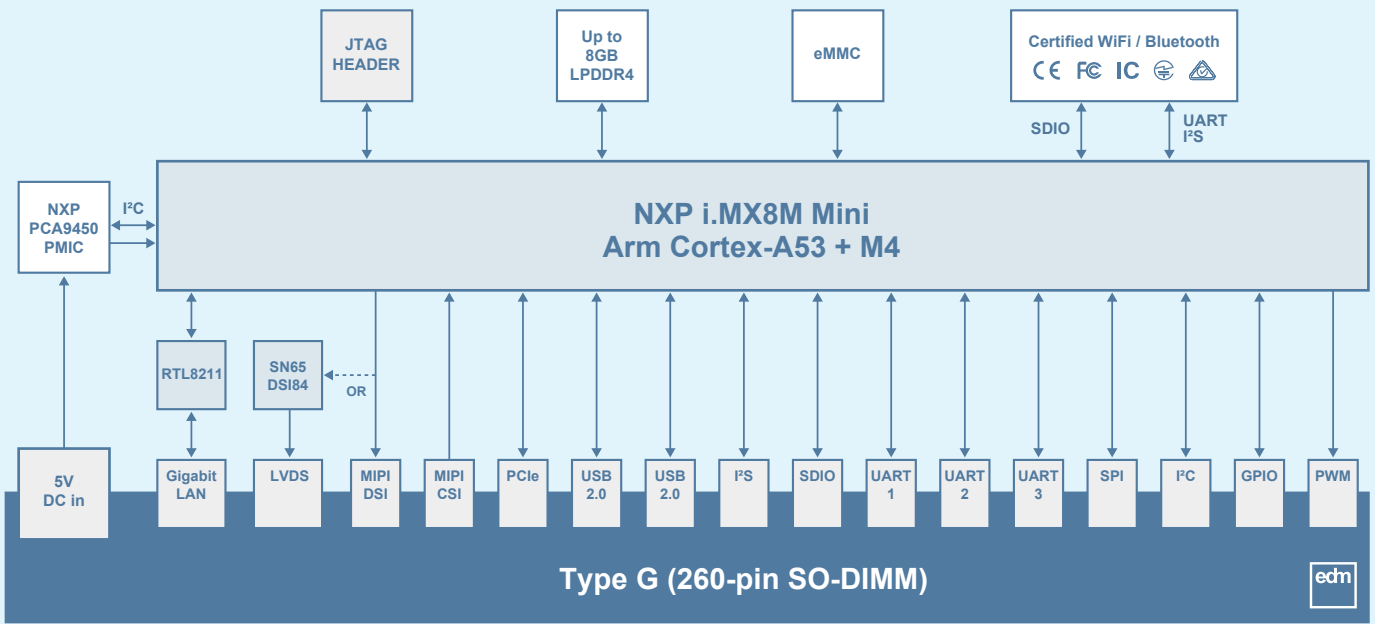

## Order Information

### EDM-G-IMX8MMQ-xx-Rxx-Exx-xxxx-xx-xxxx

Option	Code	Description
<b>Processor</b>	IMX8MMQ	NXP i.MX8M Mini
<b>Processor Speed</b>	16	1.6GHz
	18	1.8GHz
<b>Memory</b>	R10	1GB LPDDR4
	R20	2GB LPDDR4
	R40	4GB LPDDR4
	R60	6GB LPDDR4
	R80	8GB LPDDR4
<b>Storage</b>	E32	eMMC 32GB
	EXX	eMMC other capacity
<b>Wi-Fi / Bluetooth</b>	-	-
	9377	Qualcomm QCA9377 802.11a/b/g/n/ac (2.4 + 5GHz) + Bluetooth
<b>Temperature Range</b>	-	Commercial Temperature range (0° to +60°C)(Default)
	TI	Industrial Temperature range (-40° to +85°C)
<b>Custom ID</b>	XXXX	Custom Part number ID for customized Software loader and special component (BOM)

For customization, please contact your TechNexion sales representative.