

WAND REV:C1

PCB SN:100300490411

L=4, 95 x 95 mm

PAGE TITLE

- P01 Index
- P02 Expansion CONN.
- P03 DC-DC & M-SD
- P04 HOST & Client
- P05 Audio & RJ45
- P06 LVDS & HDMI & SATA

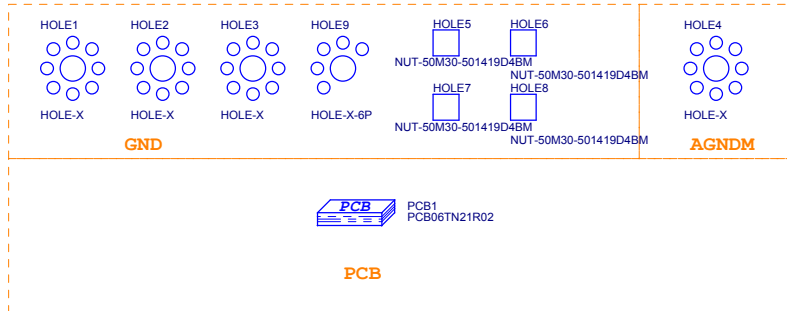

- FM1 FM40S-X
- FM2 FM40S-X
- FM3 FM40S-X
- FM4 FM40S-X
- FM5 FM40S-X
- FM6 FM40S-X
- FM7 FM40S-X
- FM8 FM40S-X

WANDBOARD DESIGN AND DISCLAIMER

These design materials referred to in this document are ***NOT SUPPORTED*** and DO NOT constitute a reference design. Only "community" support is allowed via resources at Wandboard.org forums.

THERE IS NO WARRANTY FOR THE DESIGN MATERIALS, TO THE EXTENT PERMITTED BY APPLICABLE LAW. EXCEPT WHEN OTHERWISE STATED IN WRITING THE COPYRIGHT HOLDERS AND/OR OTHER PARTIES PROVIDE THE DESIGN MATERIALS "AS IS" WITHOUT WARRANTY OF ANY KIND, EITHER EXPRESSED OR IMPLIED, INCLUDING, BUT NOT LIMITED TO, THE IMPLIED WARRANTIES OF MERCHANTABILITY AND FITNESS FOR A PARTICULAR PURPOSE. THE ENTIRE RISK AS TO THE QUALITY AND PERFORMANCE OF THE DESIGN MATERIALS IS WITH YOU. SHOULD THE DESIGN MATERIALS PROVE DEFECTIVE, YOU ASSUME THE COST OF ALL NECESSARY SERVICING, REPAIR OR CORRECTION.

This board was designed as an evaluation and development tool. It was not designed with any other application in mind. As such, these design materials may or may not be suitable for any other purposes. If used, the design material becomes your responsibility as to whether or not it meets your specific needs or your specific applications and may require changes to meet your requirements.

WANDBOARD.ORG		
Title		
INDEX		
Size Custom	Document Number	Rev C1
WAND		
Date: Monday, April 30, 2018	Sheet 1	of 6

Board to Board

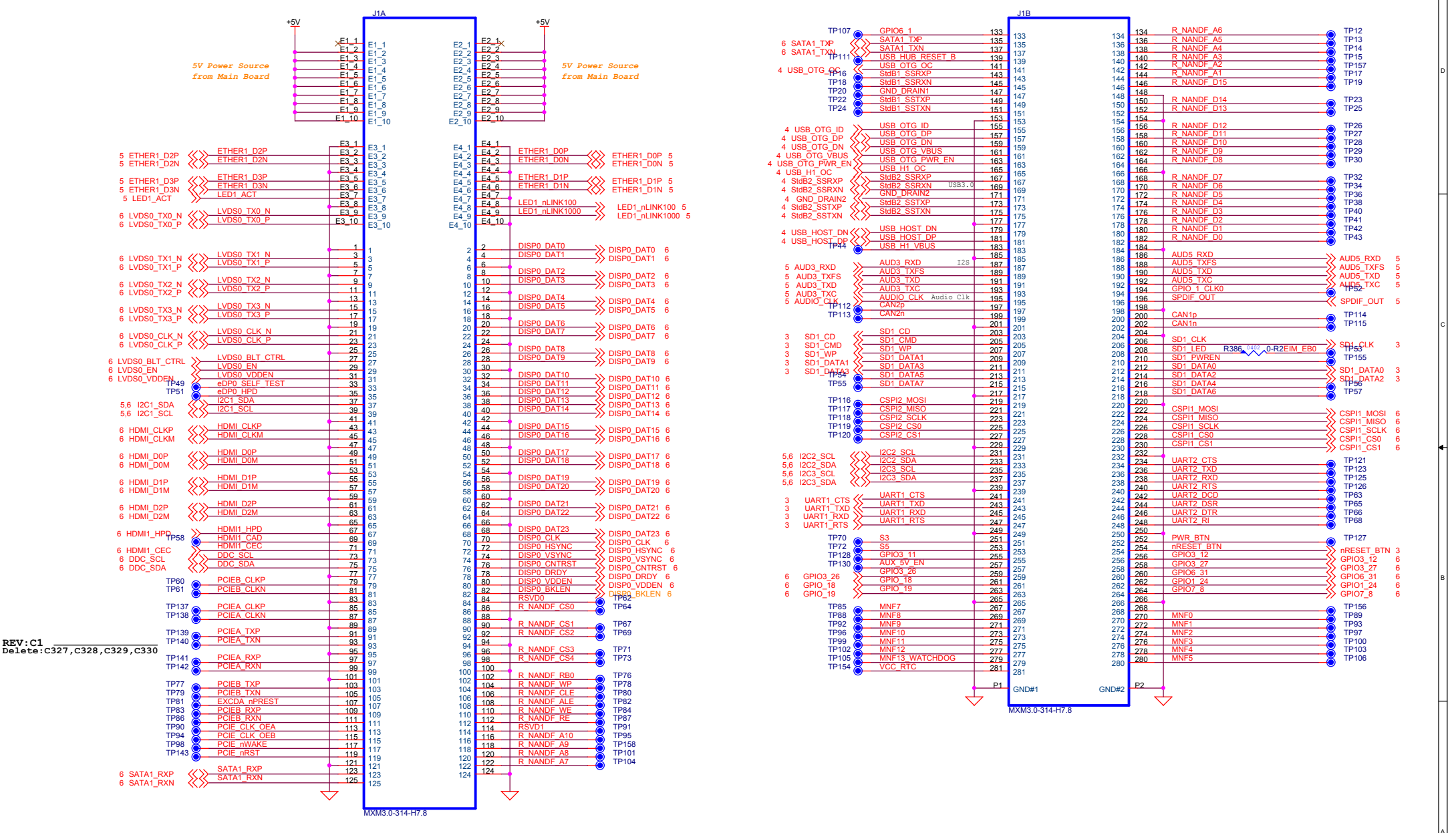

REV: C1
Delete: c327, c328, c329, c330

WANDBOARD.ORG

Title: **BLOCK DIAGRAM**

Size: Custom | Document Number: **WAND** | Rev: C1

Date: Monday, April 30, 2018 | Sheet: 2 of 6

DC JACK

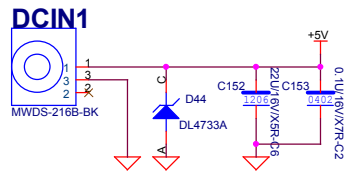

DC-DC

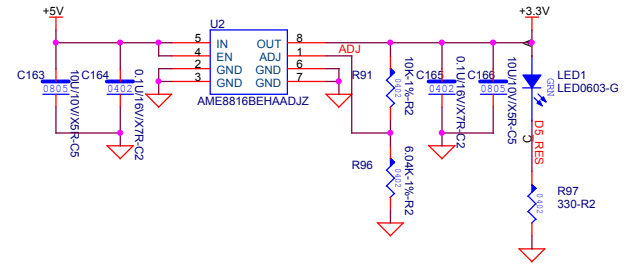

Button

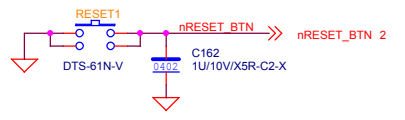

UART

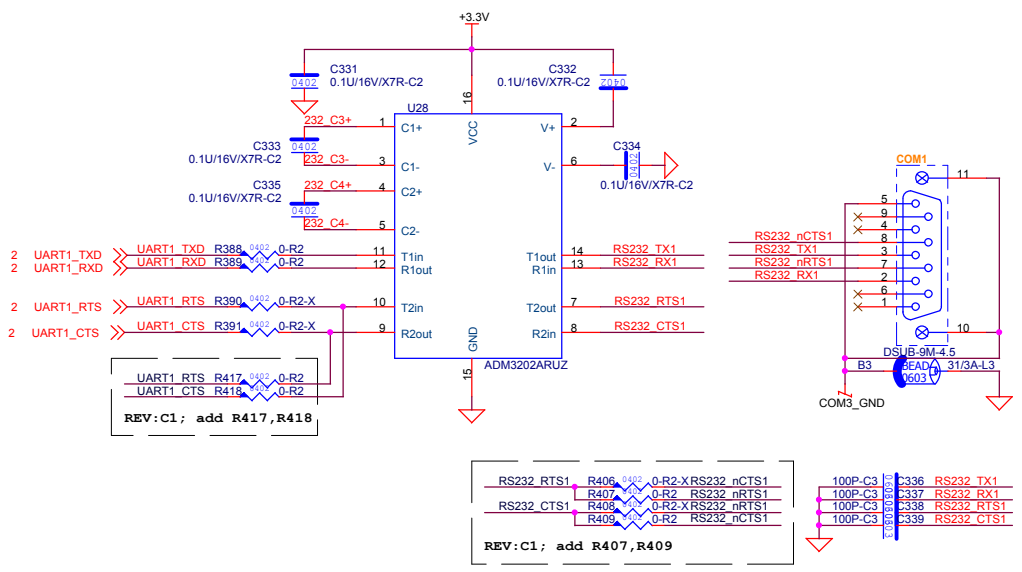

Micro-SD

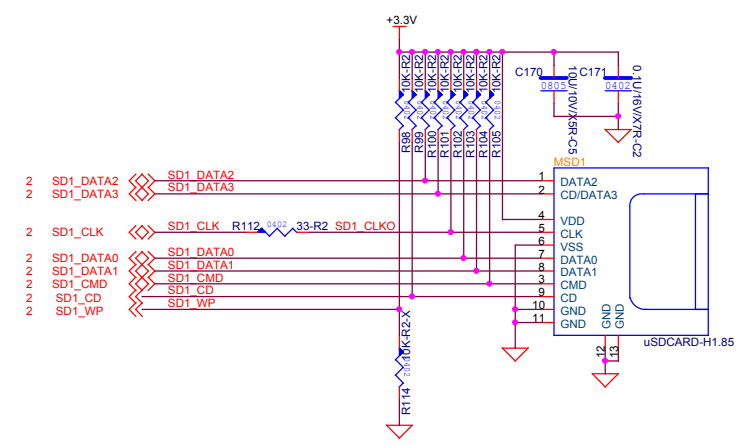

HOST USB

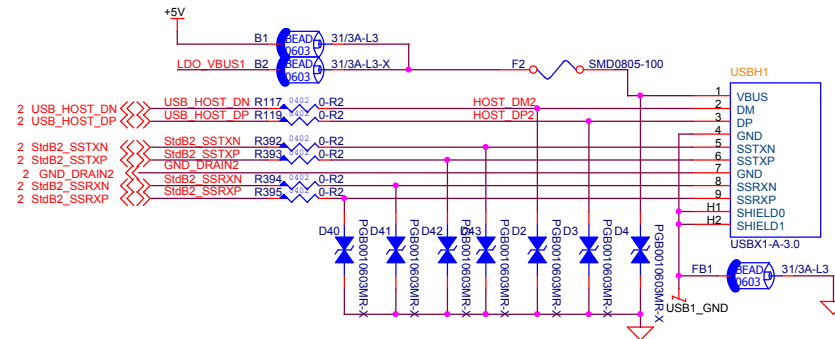
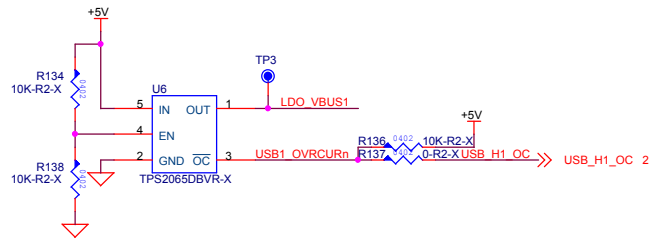

OTG USB

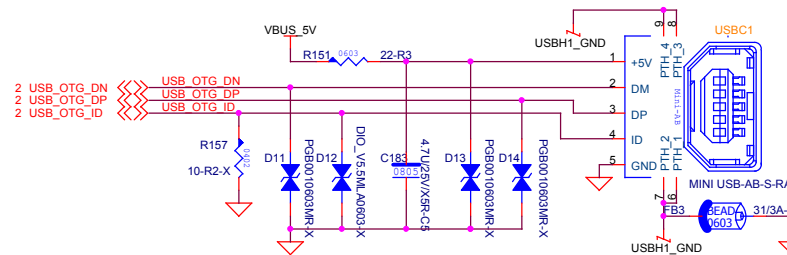
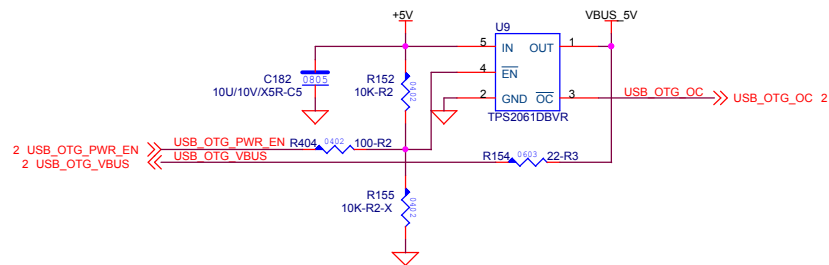

AUDIO

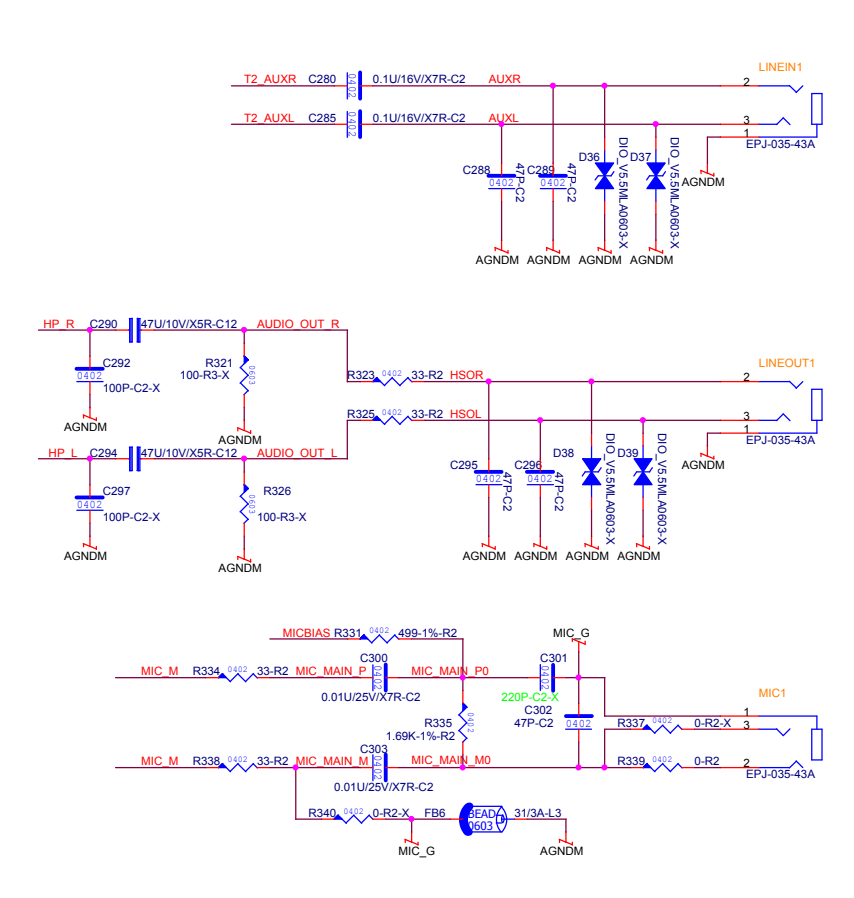
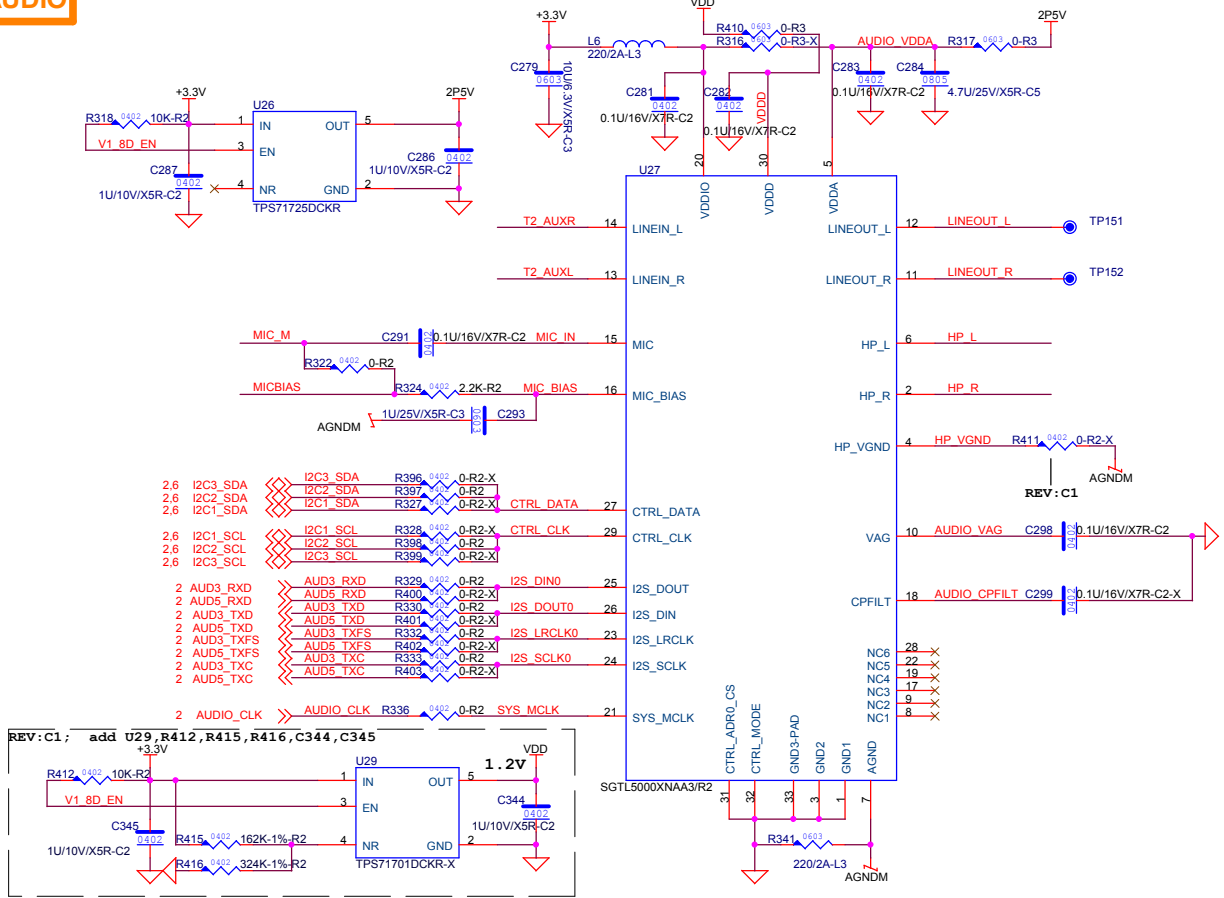

RJ45

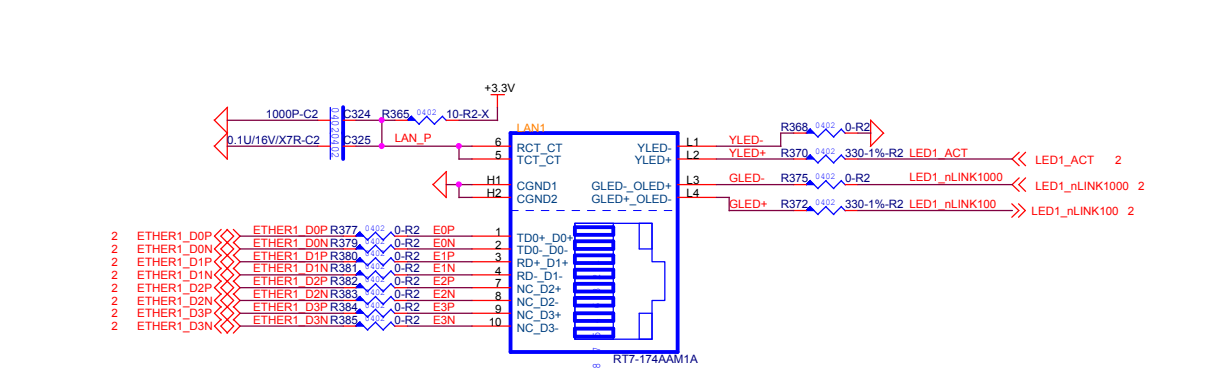

SPDIF

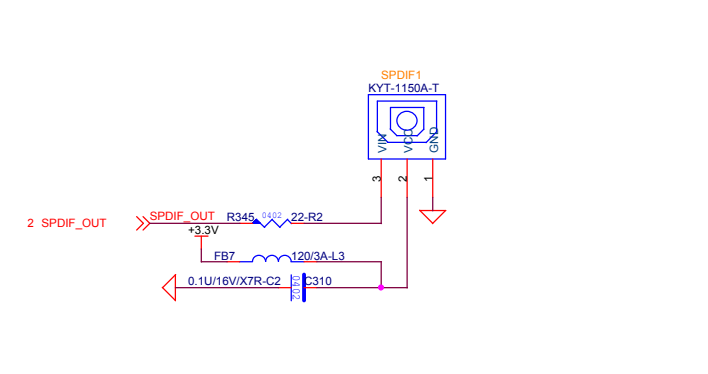

TTL

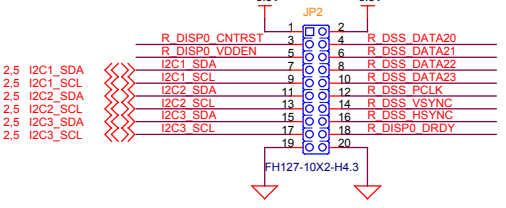
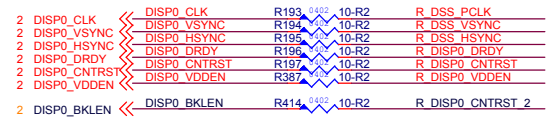
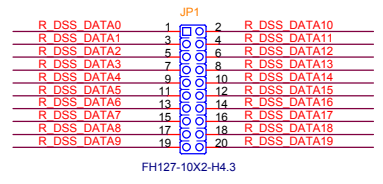
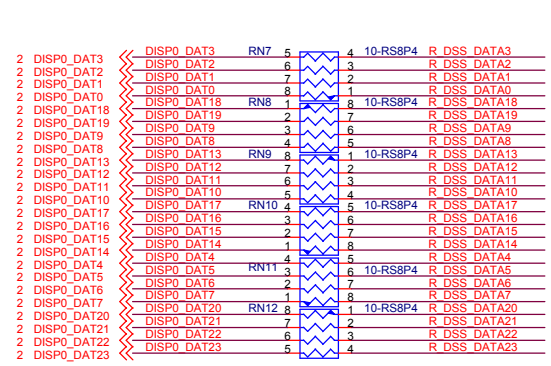

LVDS

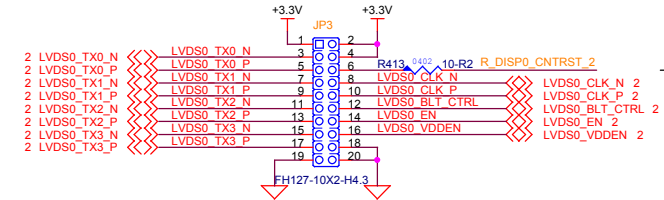

REV:C1;add R413,R414
add PWM Function

SPI

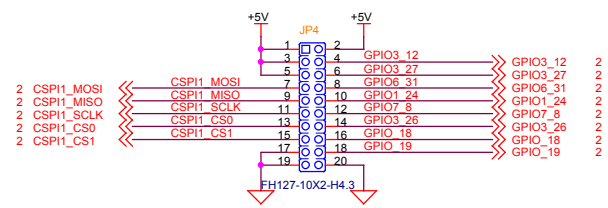

HDMI

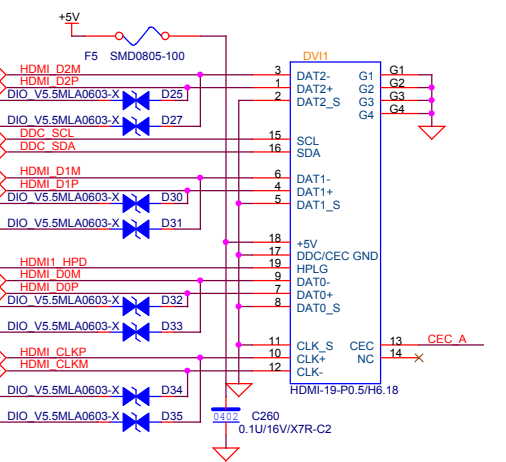
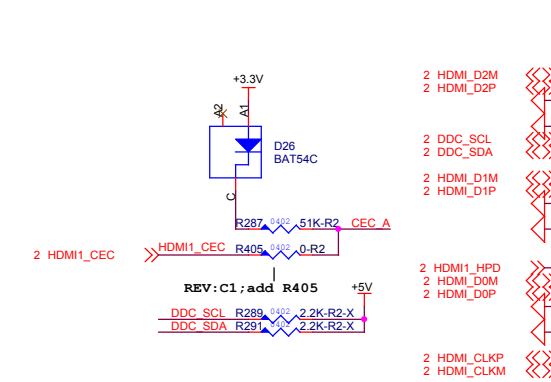

SATA

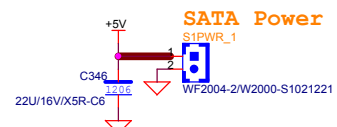
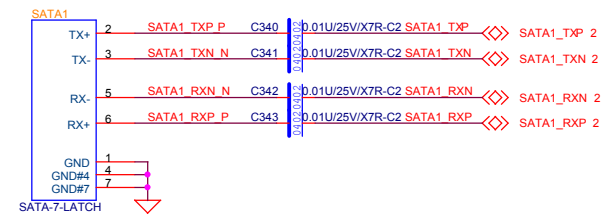

REV:C1;add C346,S1PWR_1

WANDBOARD.ORG

Title: **LVDS & HDMI & SATA**

Size: Custom | Document Number: **WAND** | Rev: **C1**

Date: Monday, April 30, 2018 | Sheet: 6 of 6