

AXON-WIZARD-IMX8M-MINI Quickstart Guide



1 Safety Precautions

Thank you for purchasing a TechNexion AXON series evaluation kit based on NXP i.MX8M MINI applications processor. This installation guide will be helpful in the installation, wiring and inspection of your TechNexion evaluation kit. Before using the product, please read this guide to ensure correct use. You should thoroughly understand all safety precautions before proceeding with the installation, wiring, and operation. Place this instruction sheet in a safe location for future reference.

1.1 Storage and Installation

- Keep the device dry. Precipitation, humidity, and all types of liquids or moisture can contain minerals that will corrode electronic circuits. If your device does get wet, allow it to dry completely.
- Do not use or store the device in dusty or dirty areas. Its parts and electronic components can be damaged.
- Do not store the device in hot areas. High temperatures can shorten the life of electronic devices, damage batteries, and warp or melt certain plastics.
- Do not store the device in cold areas. When the device returns to its normal temperature, moisture can form inside the device and damage electronic circuit boards.
- This product is designed for specific applications and needs to be installed by qualified personnel.
- Do not drop, knock, or shake the device. Rough handling can break internal circuit boards and fine mechanics.
- Do not paint the device. Paint can clog the parts and prevent proper operation.
- Unauthorized modifications or attachments could damage the device and may violate regulations governing radio devices.

1.2 Wiring

- Make sure that the available power source matches the required input power of the device. Failure to observe this caution may result in electric shock or fire.

1.3 Maintenance and Inspection

- Do not touch any internal or exposed parts of the device as electrical shock may result.
- Do not open the device while power is on. Otherwise electrical shock may result.
- Do not use harsh chemicals, cleaning solvents, or strong detergents to clean the device.
- Be sure the ventilation holes are not obstructed during operation. Otherwise malfunction may result due to bad ventilation or overheating.

These suggestions apply equally to your device, battery, charger, or any enhancement. If any device is not working properly, take it to the nearest authorized service facility for service.

2 Dimensions

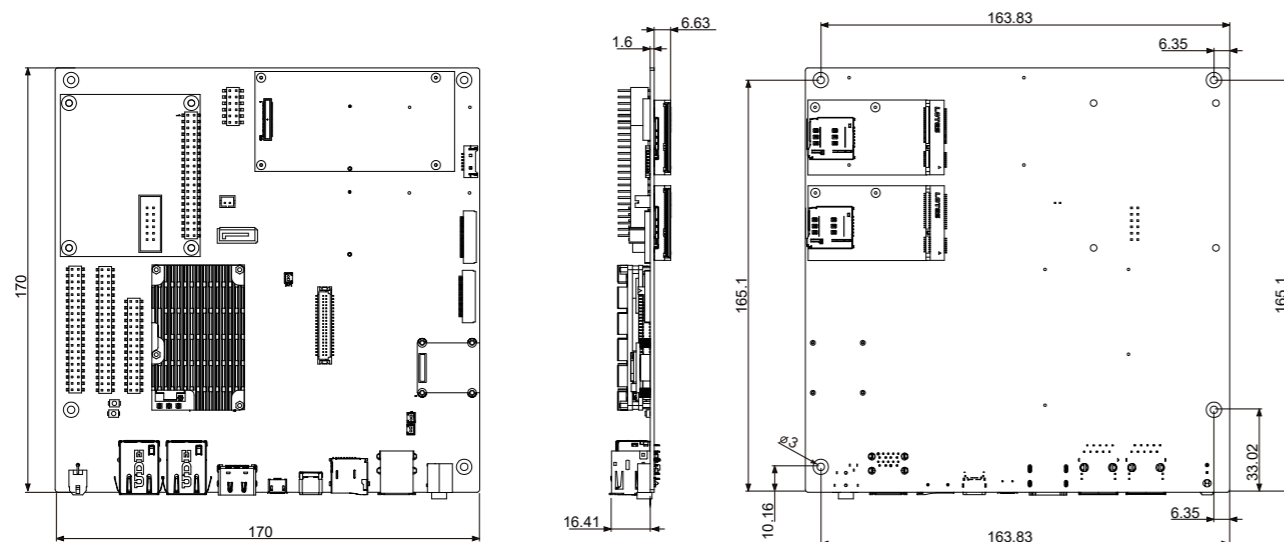

Unit : mm

3 Installation Instructions

This installation guide will help you to assemble your development kit using step-by-step instructions to make sure all parts (development board, display, camera module and Wi-Fi antenna) are working.

3.1 Connect the parts

Connect the parts in the following order. Note that some versions of the AXON-WIZARD-IMX8M-MINI evaluation kit do not include the multi-touch display, camera / HDMI capture module and/or HDMI expander card.
Tips: Do not power your board during the installation process.

3.2 Standoffs (optional)

Let's prepare four standoffs It only takes a few minutes.

Step 1: Prepare evaluation board and standoffs.

Step 2: Locate four standoffs holes on the evaluation board.

Step 3: Locate a screw and insert it into the hole. Screw a standoff on the underside. Attach the standoffs for the remaining three holes.

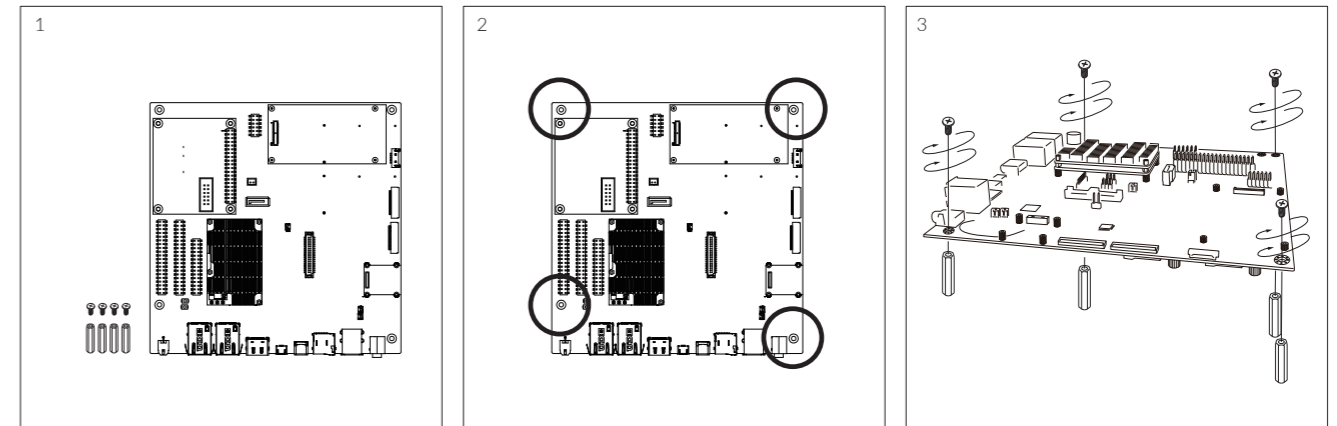

3.3 Camera module / HDMI capture card (optional)

Please follow the steps below to properly install the camera module. The same steps can be applied to the installation of the HDMI capture card.

Step 1: Prepare camera module, FPC cable and evaluation board.

Step 2: Turn the camera module over to reveal a white connector near the edge of the module. Swivel the black retaining clip upward.

Step 3: Insert either end of the camera module cable into the white connector. Make sure that the blue side of the ribbon is facing up and is aligned straight with the connector. The silver pins on the FPC cable should be facing down.

Step 4: Swivel the retaining clip back down to hold the FPC cable in place.

Steps 5 and 6: Repeat these same steps with the other end of the cable and the connector on the board.

Tips: After installation remove the protective blue film from the camera lens.

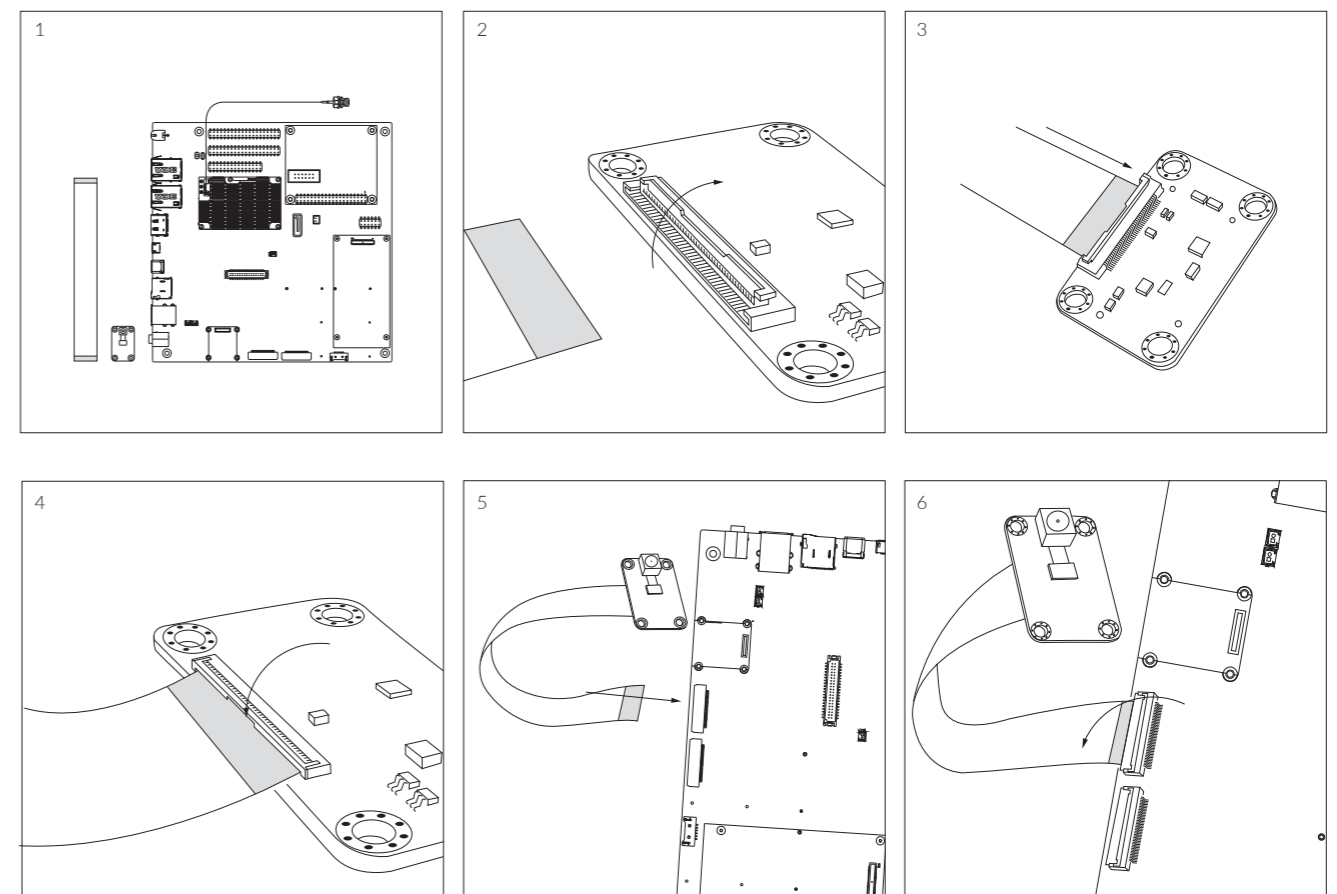

3.4 Display (optional)

- If you buy your evaluation kit with 8" or 10.1" panel, please refer to the separate 8" / 10.1" panel installation guide included with the panel for more details. After you finish the panel installation, return to this guide.

Please follow the steps below to properly install the 5" display.

Step 1: Prepare evaluation board, MIPI expander board and screws.

Step 2: Locate the MIPI expander board and align the 70-pin connectors, gently press the connector on the back of the expander board onto the connector on the evaluation board until you hear a click sound.

Step 3: Use three screws to secure the MIPI expander board to the development board.

Step 4: Locate the MIPI Display connectors on the expander board. Swivel the black retaining clips upward.

Step 5: Insert end of the TOUCH and MIPI Display FPC cables into the connectors on the board. The silver pins on the FPC cable should be facing down. Then swivel the retaining clips back down to hold the FPC cables in place.

Step 6: Remove the protective transparent film from the display.

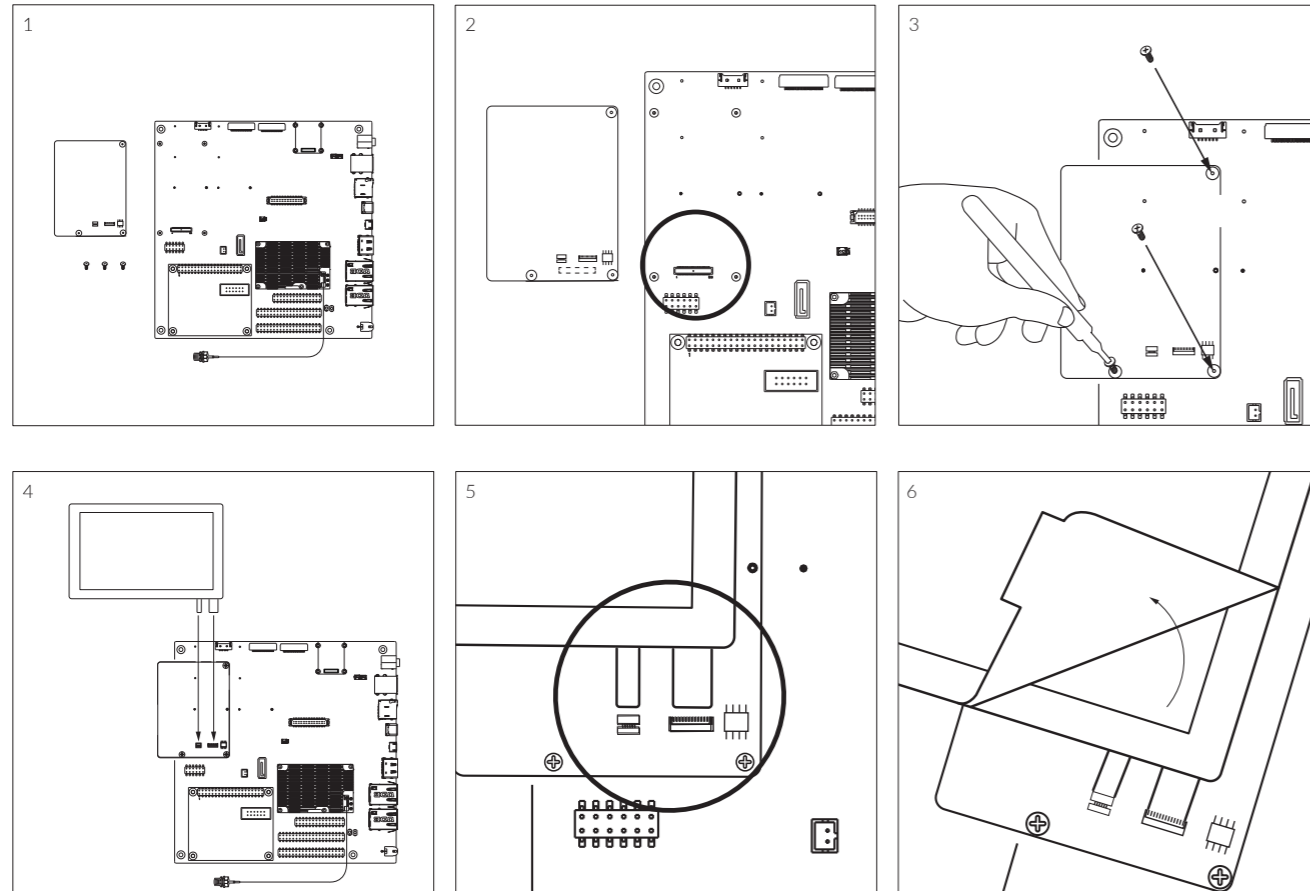

3.5 Final steps

Now your kit is almost assembled.

Step 1: Connect the RTC backup battery.

Step 2: Attach the extender cable to the Wi-Fi antenna.

Step 3: Connect the 2-pin Micro-Fit 3.0 cable to power up the evaluation kit.

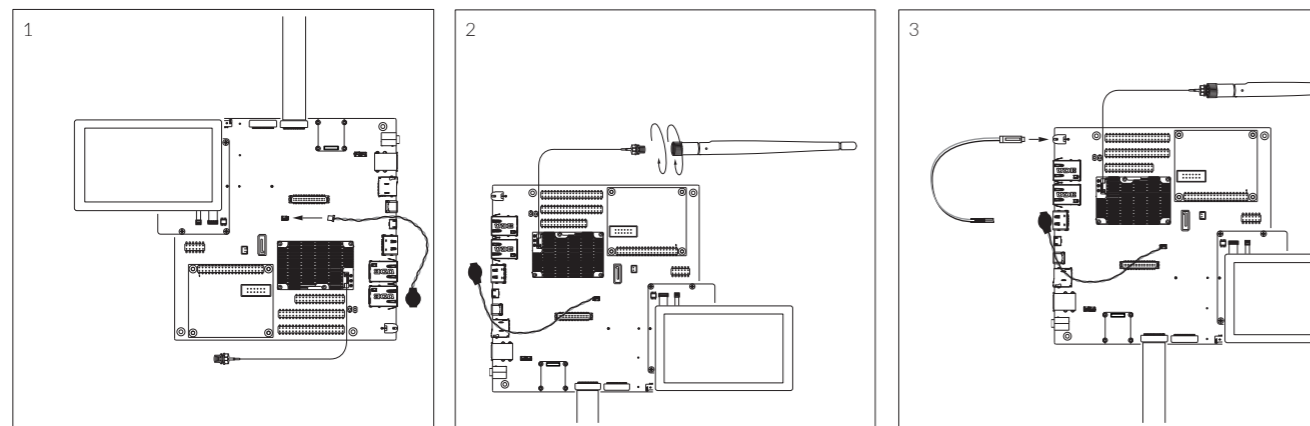

4 Pin Definition

4.1 Power Connector (DCIN1 +12v)

This product features one 2-pin Micro-Fit 3.0 power connector: DCIN1 +12v.

Header	Pin #	Signal	Description
	1	GND	Ground
	2	VCC	DC Voltage input (12V DC)

Header on AXON-WIZARD-IMX8M-MINI: Molex 43045-0212 (2-pin Micro-Fit 3.0).

Cable receptacle: Molex 43025-0200 (2-pin Micro-Fit 3.0) plug with crimp contact Molex 43030-0007.

4.2 SWITCH1-8 Default Boot Mode Switches

The AXON-WIZARD-IMX8M-MINI features internal Default Boot Mode setting.

Device	SW1-1	SW1-2
eMMC	OFF	OFF
SDIO	ON	OFF
USB_A_OTG	OFF	ON

NOTE: *SW1 is OFF by default. In order to boot from eMMC.

*BOOTCTRL0_1 should be high by default.

5 External Connectors

Front view:

Rear view:

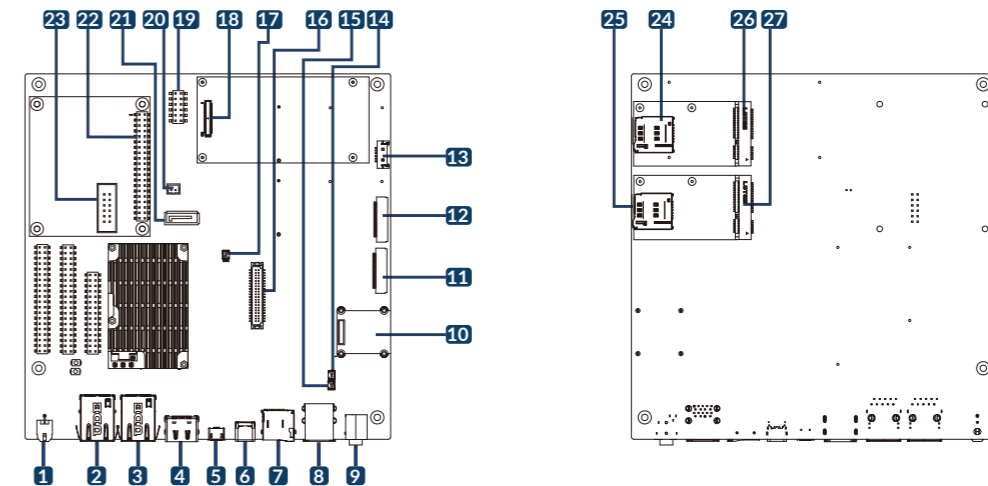

No.	Description	No.	Description
1	Power Input connector	15	L-Speaker connector
2	LAN2 RJ45 connector	16	LVDS connector
3	LAN1 RJ45 connector	17	RTC Battery connector
4	HDMI connector	18	MIPI Display connector
5	CONSOLE connector	19	Audio channel selection
6	USB OTG (Type-C) connector	20	SATA_PWR_1 connector
7	Micro-SD1 card slot	21	SATA1 connector
8	USB Host connectors (2x)	22	40-pin expansion header
9	Audio Jack	23	12-pin expansion header
10	CLIX connector	24	Micro-SIM1 card slot
11	MIPI Camera 1 connector	25	Micro-SIM2 card slot
12	MIPI Camera 2 connector	26	mini-PCIe1 connector
13	Touch connector	27	mini-PCIe2 connector
14	R-Speaker connector		

6 Software Installation

The unit is preloaded with software that can download and install a selection of OS images over hardwired network. Simply connect a network to the unit through the LAN RJ45 connector and power it up, then follow the steps on the screen to load the software. Local proxies will interfere with this process. For more information, go to our Knowledge Base at: <https://www.technexion.com/support/knowledge-base/>

- All Rights Reserved. No part of this document may be photocopied, reproduced, stored in a retrieval system, or transmitted, in any form or by any means whether, electronic, mechanical, or otherwise without the prior written permission of TechNexion Ltd.
- No warranty of accuracy is given concerning the contents of the information contained in this publication. To the extent permitted by law no liability (including liability to any person by reason of negligence) will be accepted by TechNexion Ltd., its subsidiaries or employees for any direct or indirect loss or damage caused by omissions from or inaccuracies in this document.
- TechNexion Ltd. reserves the right to change details in this publication without notice. Please download the most updated version at: <https://www.technexion.com/support/download-center/>