

EDM1-FAIRY REV:A2

L=6, 147 x 102 mm(5.8" x 4")

PAGE TITLE

P01 Index

P02 Expansion CONN.

P03 DC-DC& M-SD & BatterySocket

P04 USB Host

P05 USB Ports & CAN bus

P06 HDMI & Others

P07 RS232/422/485

P08 Others

P09 Audio_1/Audio_2

P10 RJ45 & EEPROM/ SPDIF

P11 LVDS & CONNs

P12 Touch & 3G & MNF

DESIGN AND DISCLAIMER

These design materials referred to in this document are *NOT SUPPORTED* and DO NOT constitute a reference design.

THERE IS NO WARRANTY FOR THE DESIGN MATERIALS, TO THE EXTENT PERMITTED BY APPLICABLE LAW. EXCEPT WHEN OTHERWISE STATED IN WRITING THE COPYRIGHT HOLDERS AND/OR OTHER PARTIES PROVIDE THE DESIGN MATERIALS "AS IS" WITHOUT WARRANTY OF ANY KIND, EITHER EXPRESSED OR IMPLIED, INCLUDING, BUT NOT LIMITED TO, THE IMPLIED WARRANTIES OF MERCHANTABILITY AND FITNESS FOR A PARTICULAR PURPOSE. THE ENTIRE RISK AS TO THE QUALITY AND PERFORMANCE OF THE DESIGN MATERIALS IS WITH YOU. SHOULD THE DESIGN MATERIALS PROVE DEFECTIVE, YOU ASSUME THE COST OF ALL NECESSARY SERVICING, REPAIR OR CORRECTION.

This board was designed as an evaluation and development tool. It was not designed with any other application in mind. As such, these design materials may or may not be suitable for any other purposes. If used, the design material becomes your responsibility as to whether or not it meets your specific needs or your specific applications and may require changes to meet your requirements.

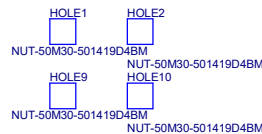
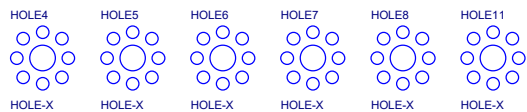

GND

PCB

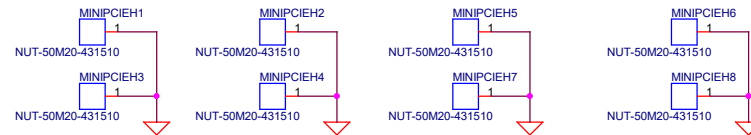

TechNexion		
INDEX		
Title		
Size Custom	Document Number	Rev A2
EDM1-FAIRY		
Date:	Wednesday, December 09, 2020	Sheet 1 of 13

Board to Board

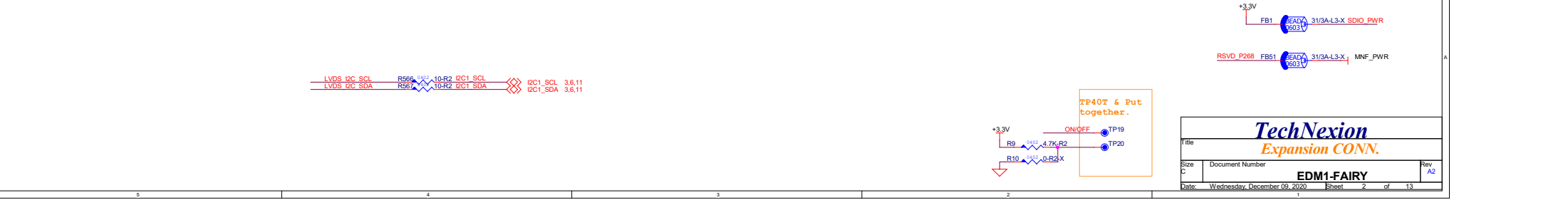
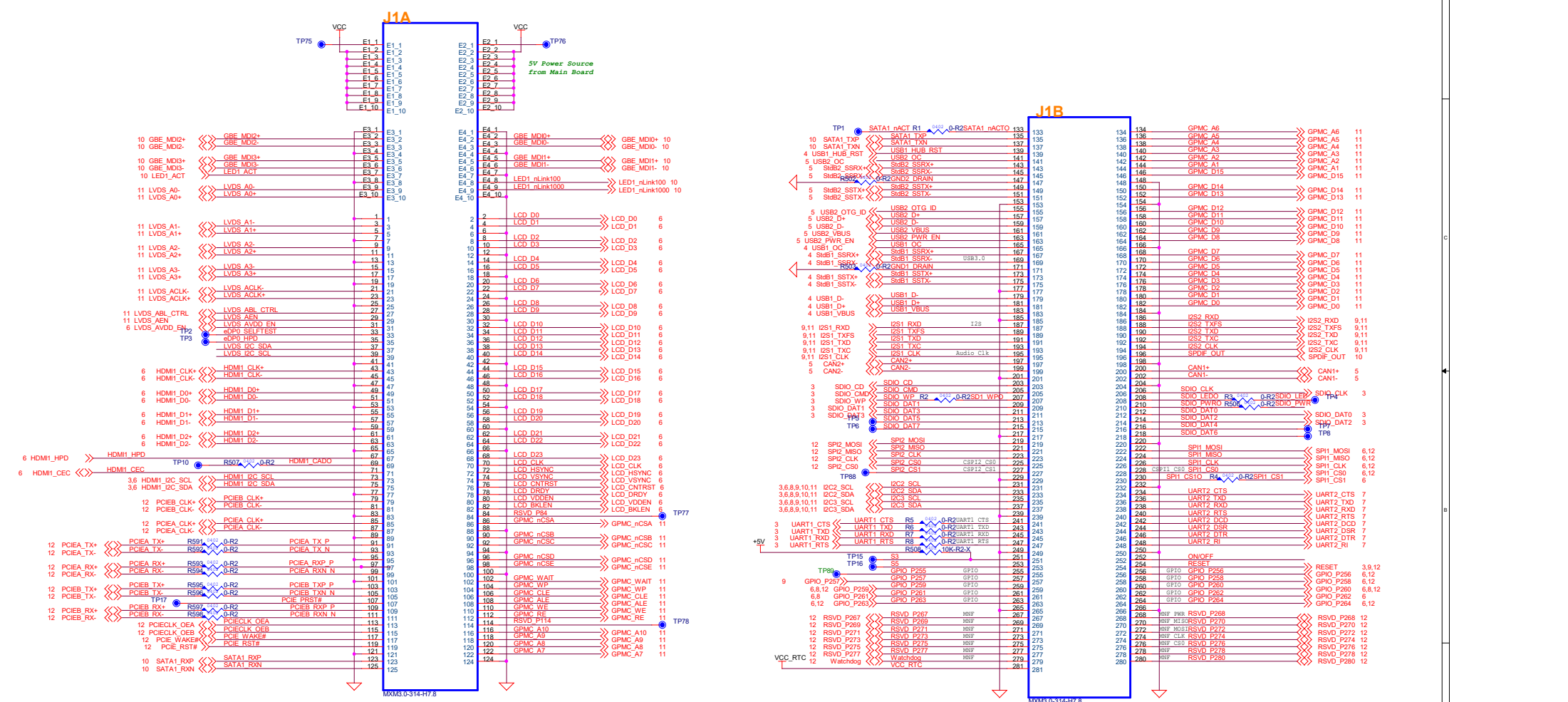

TechNexion
Expansion CONN.

File	313A-4.3-X		Rev
Size	Document Number	EDM1-FAIRY	
C		AZ	
Date	Wednesday, December 09, 2020	Sheet	2 of 13

DCIN1

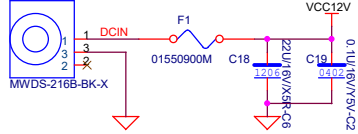

DCIN2

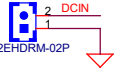

RESET1

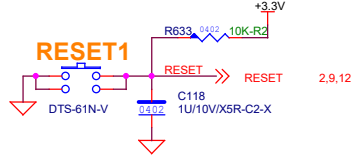

J9

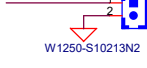

Battery Module Socket

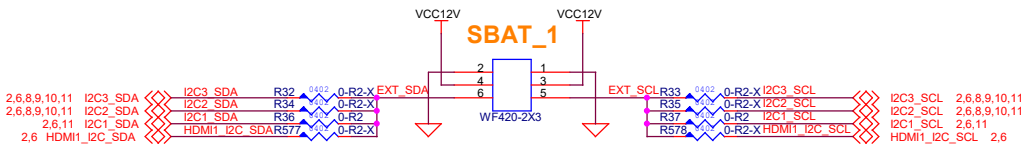

Use: I2C1 Prepare: I2C1 I2C2 I2C3

DC-DC

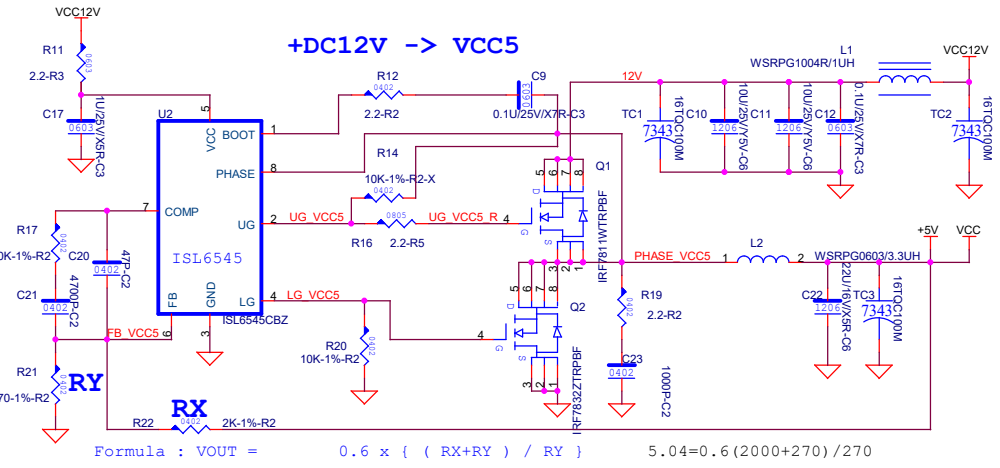
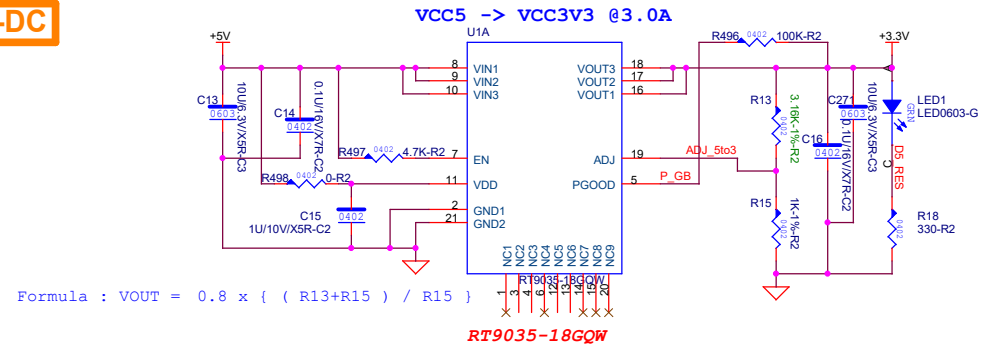

COM1

UART1 for Console

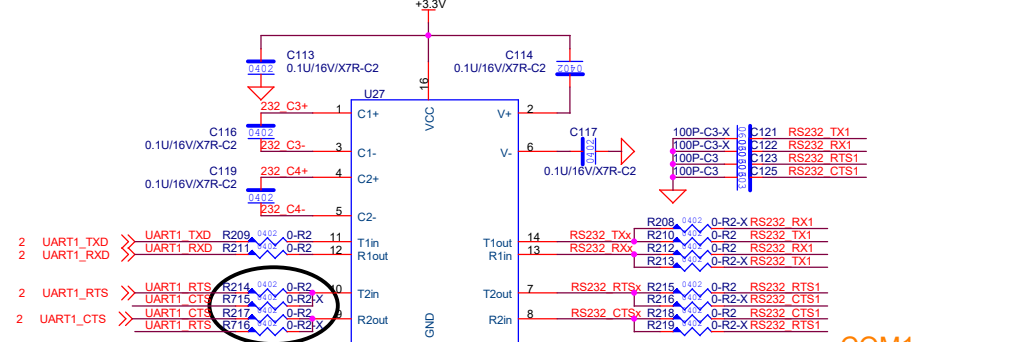

COM1

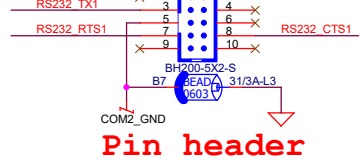

Pin header

Micro-SD

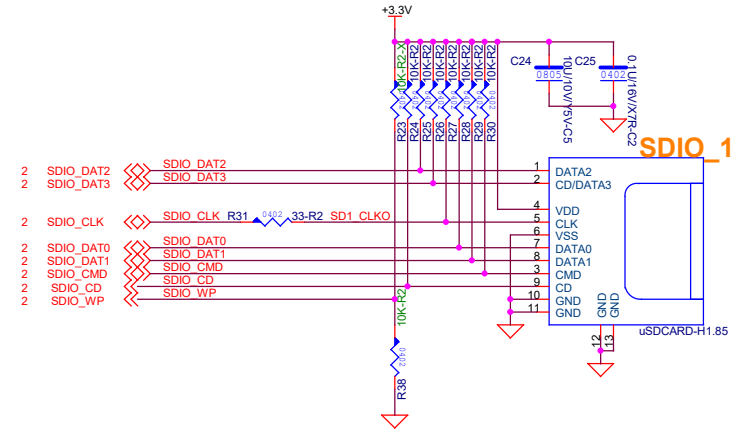

TechNexion

Title		
DC-DC & M-SD & BatterySocket		
Size	Document Number	Rev
Custom	EDM1-FAIRY	A2
Date:	Wednesday, December 09, 2020	Sheet 3 of 13

USB 3.0 Port 0

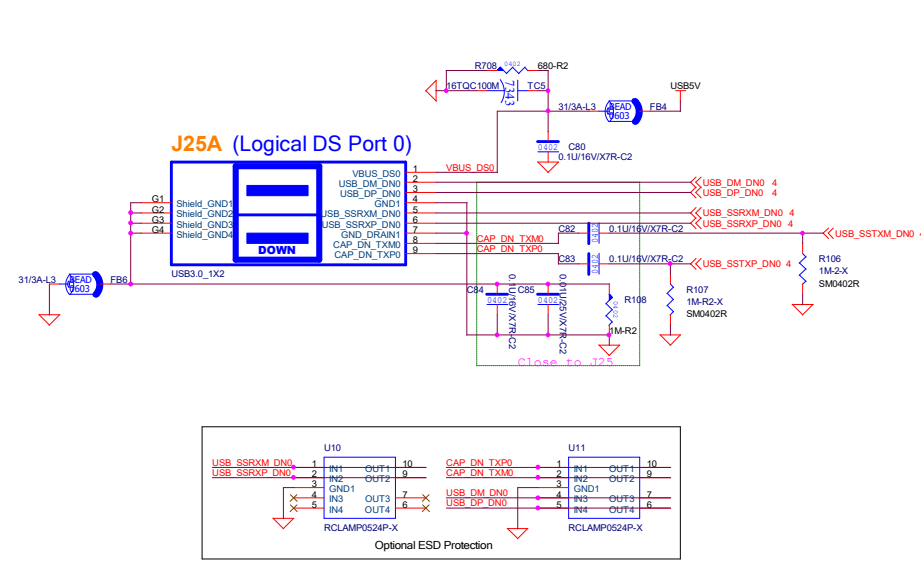

USB OTG

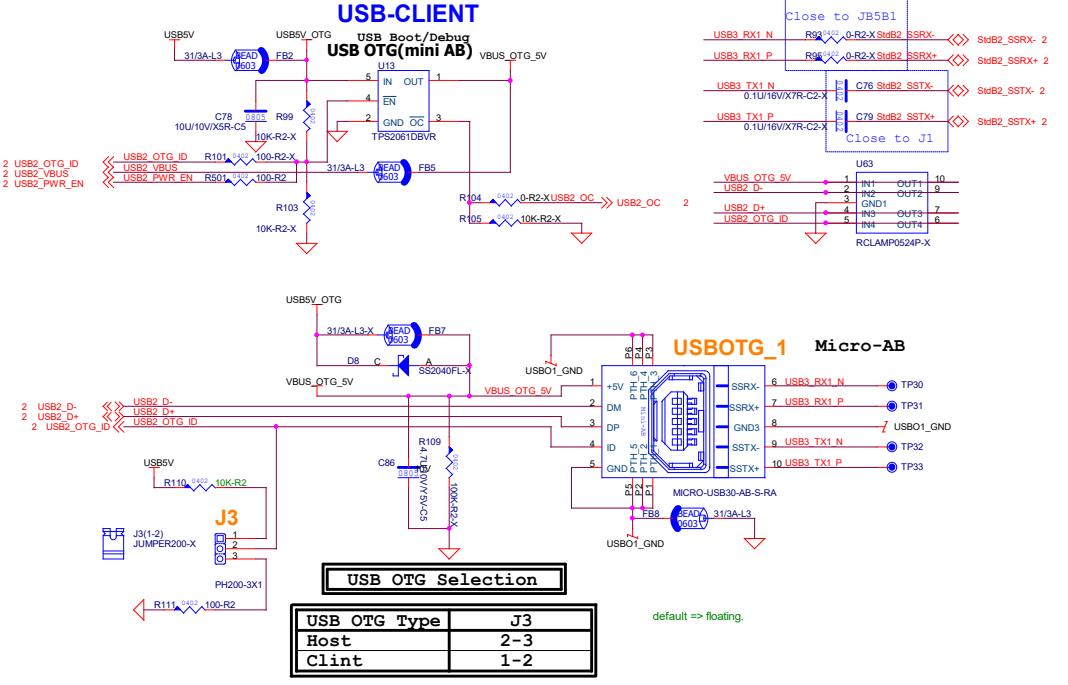

USB 3.0 Port 1

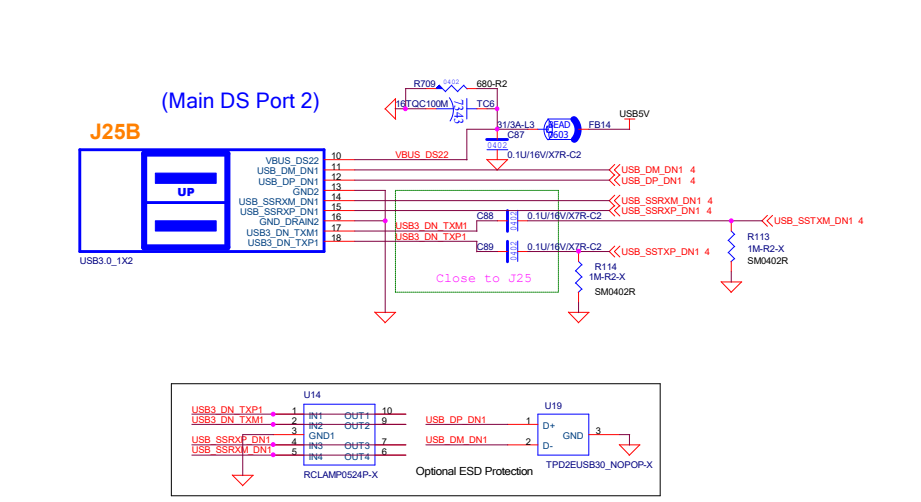

CAN Bus x 2

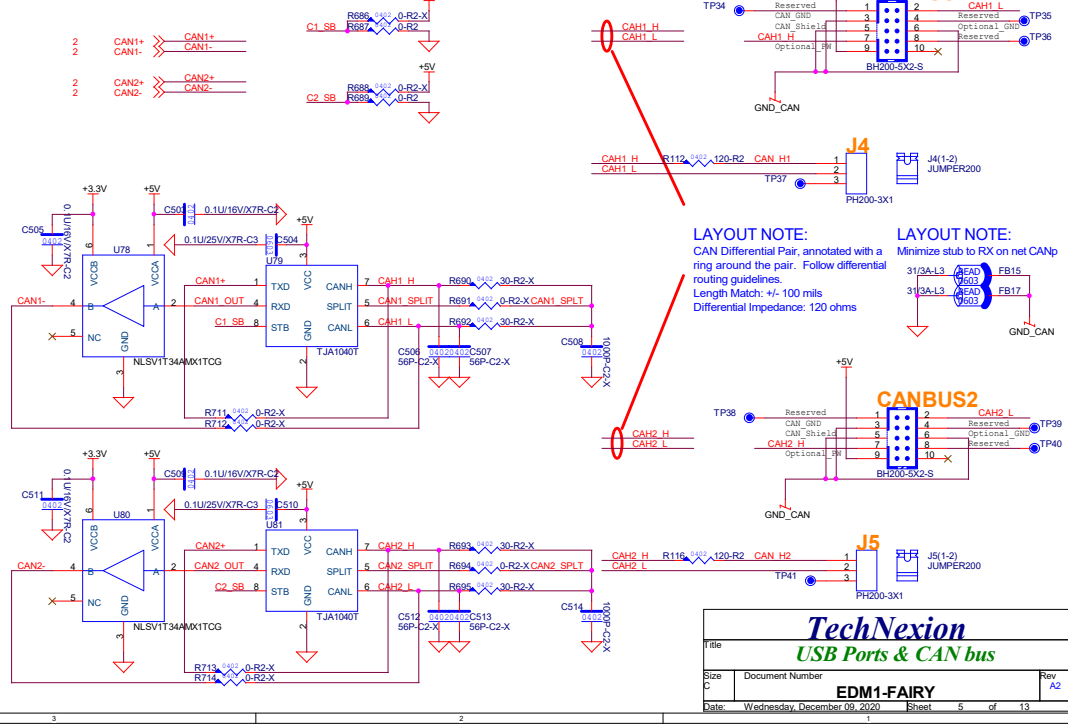

TTL

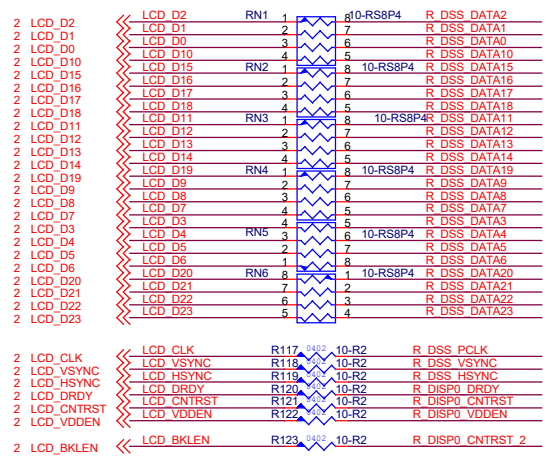

Headers JP1~4

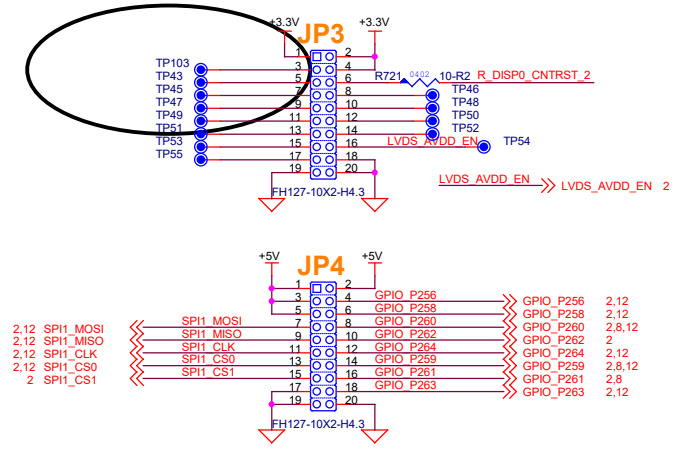
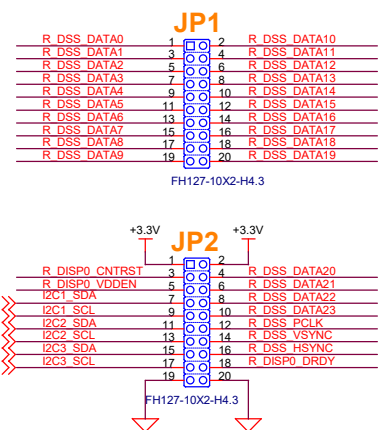

HDMI

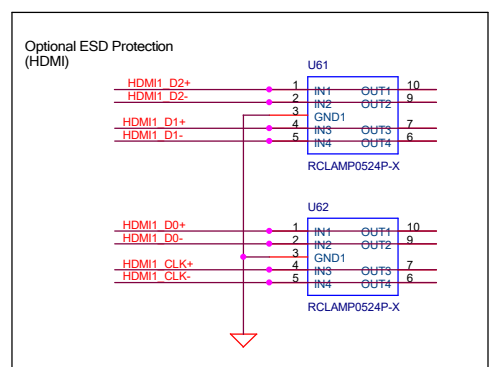
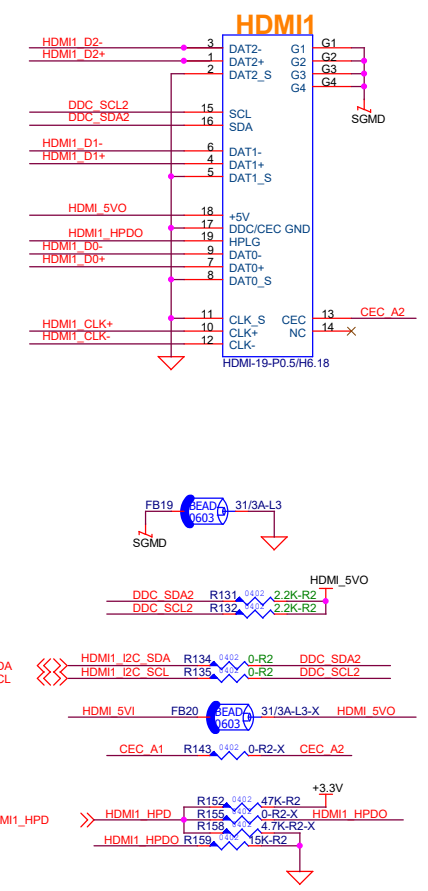
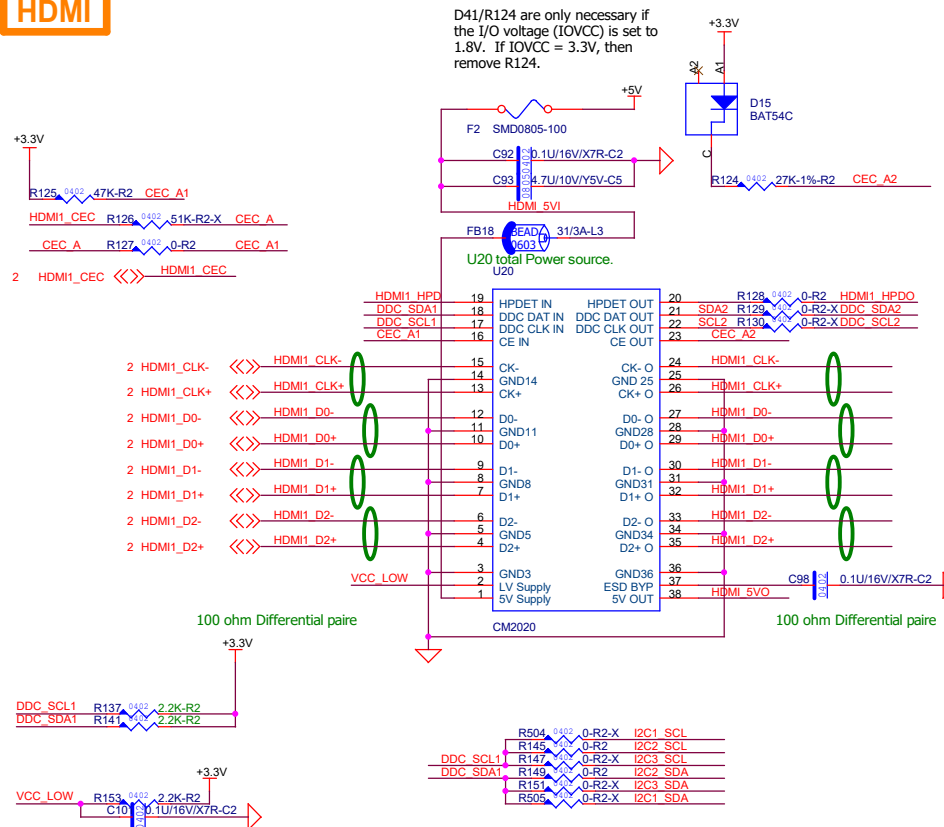

RS232

Uart2

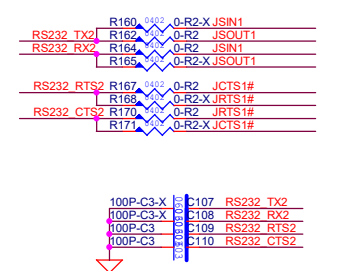
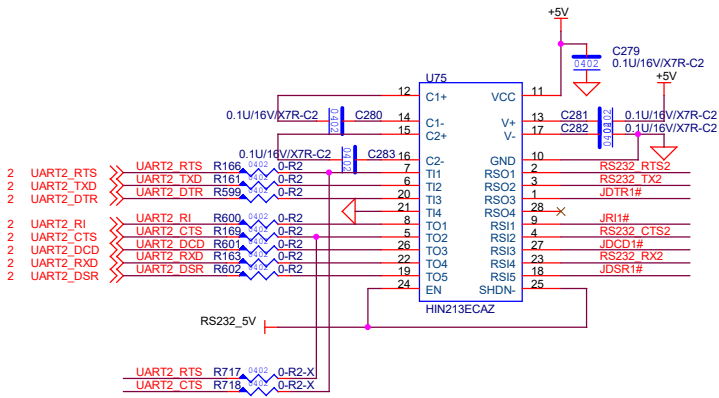

RS232/422/485 @ DB-9

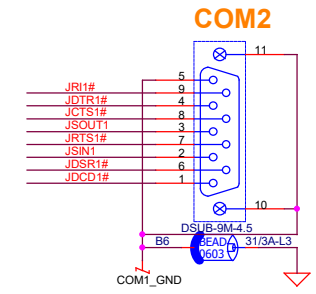

RS422/485

Uart2



RS-422/485

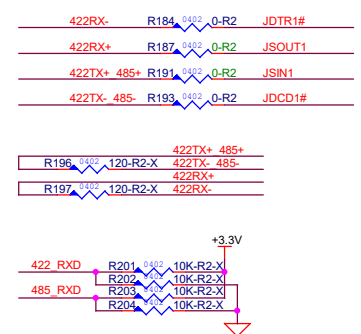
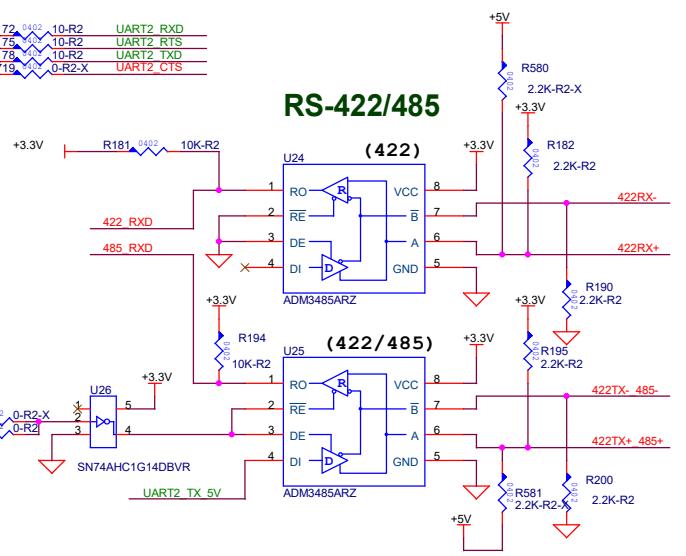

Audio Output SELECT

SW1	SGTL5000	TLV320
4-5	OFF	ON

SW1

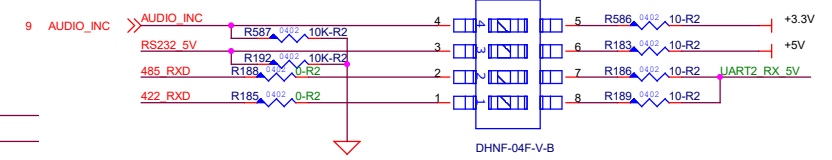

RS-232/485/422 SELECT (Com2)

SW1	RS-422	RS-485	RS-232
1-8	ON	OFF	OFF
2-7	OFF	ON	OFF
3-6	OFF	OFF	ON

TechNexion
RS232/422/485

Title		Rev A2	
Size Custom	Document Number	EDM1-FAIRY	
Date:	Wednesday, December 09, 2020	Sheet	7 of 13

RTC

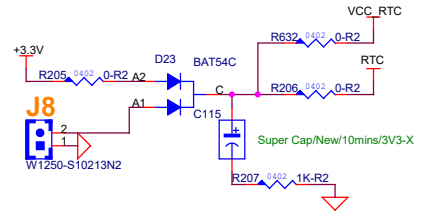

I2C SEL @ RTC

J10	I2C2	default	I2C3
1-2	ON	OFF	I2C3
3-4	OFF	ON	I2C2
5-6	OFF	ON	I2C3
7-8	ON	OFF	I2C2

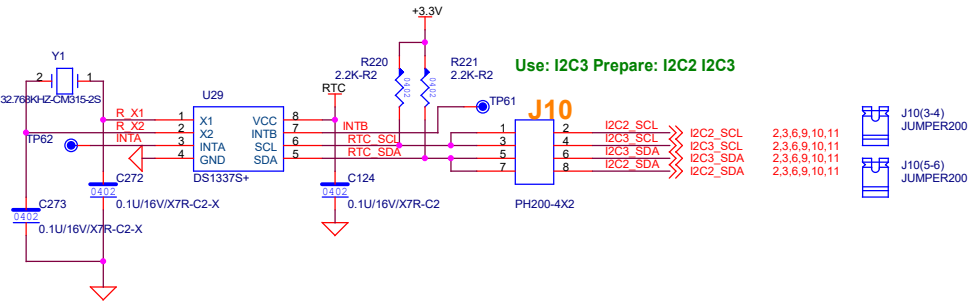

3 axis sensor

I2C SEL @ 3 axis sensor

J13	I2C2	default	I2C3
1-2	ON	OFF	I2C3
3-4	OFF	ON	I2C2
5-6	OFF	ON	I2C3
7-8	ON	OFF	I2C2

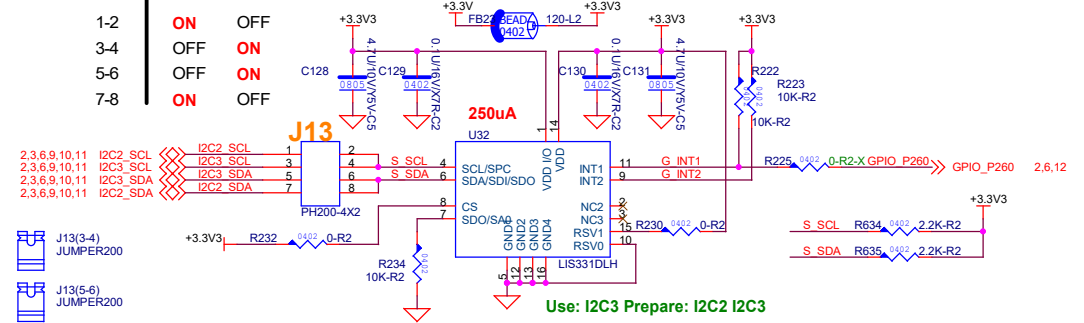

eCOMPASS

I2C SEL @ eCOMPASS

J12	I2C2	default	I2C3
1-2	ON	OFF	I2C3
3-4	OFF	ON	I2C2
5-6	OFF	ON	I2C3
7-8	ON	OFF	I2C2

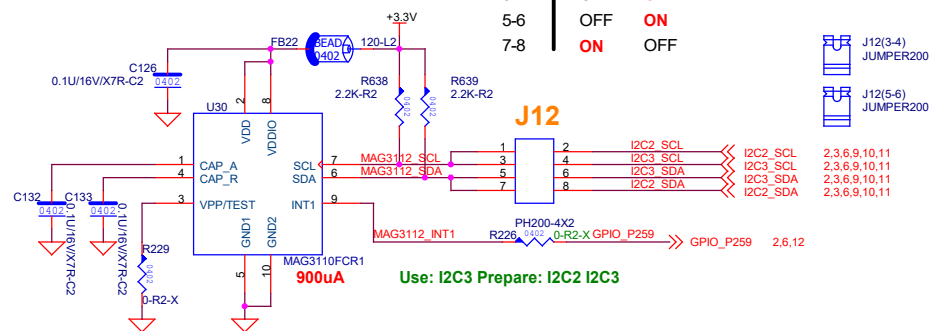

LIGHT-SENSOR

I2C SEL @ Light-Sensor

J11	I2C2	default	I2C3
1-2	ON	OFF	I2C3
3-4	OFF	ON	I2C2
5-6	OFF	ON	I2C3
7-8	ON	OFF	I2C2

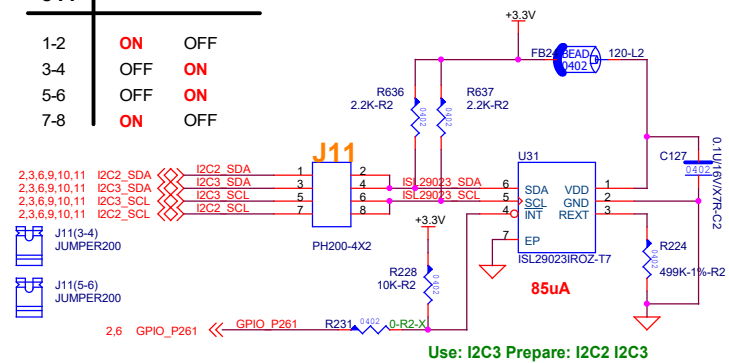

TechNexion
Others

Title		Rev	
Document Number		A2	
Size Custom		EDM1-FAIRY	
Date:	Wednesday, December 09, 2020	Sheet	8 of 13

AUDIO AMP

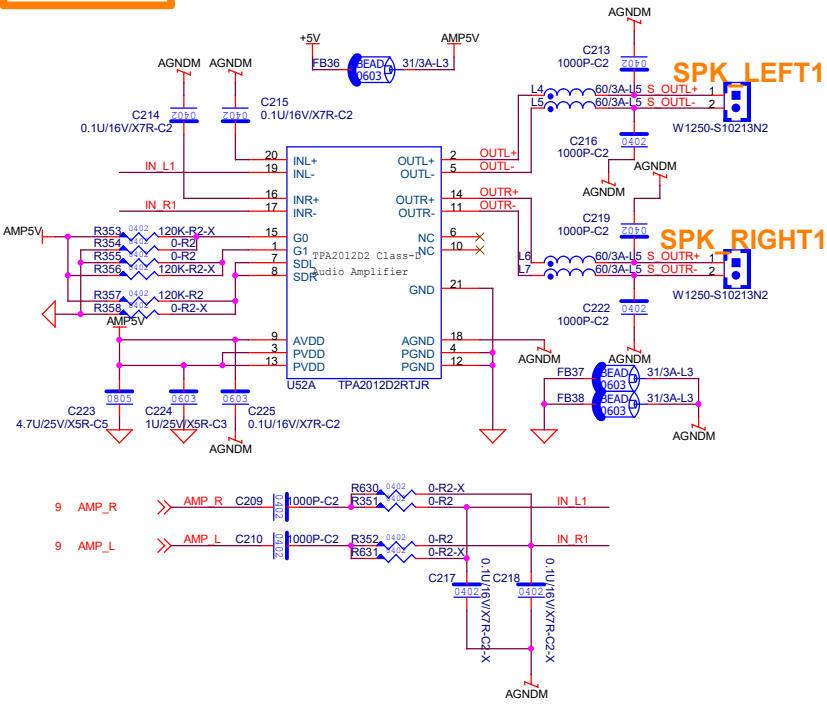

SPDIF

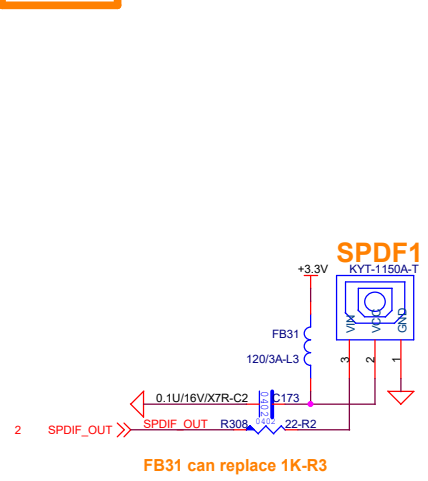

SATA

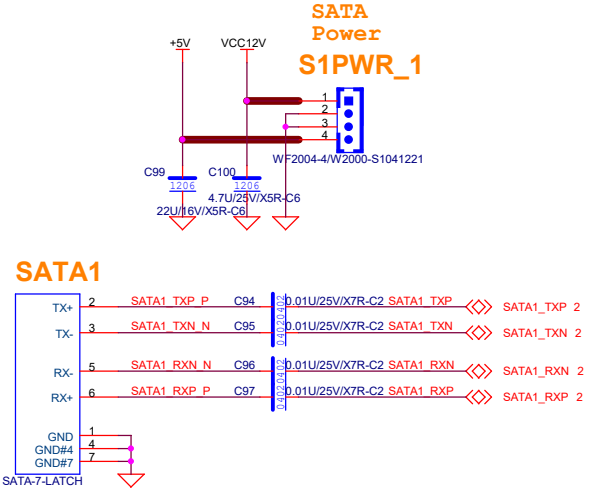

RJ45

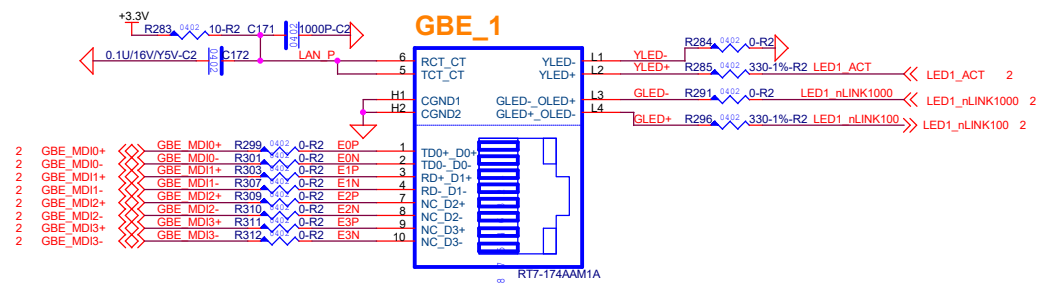

EEPROM

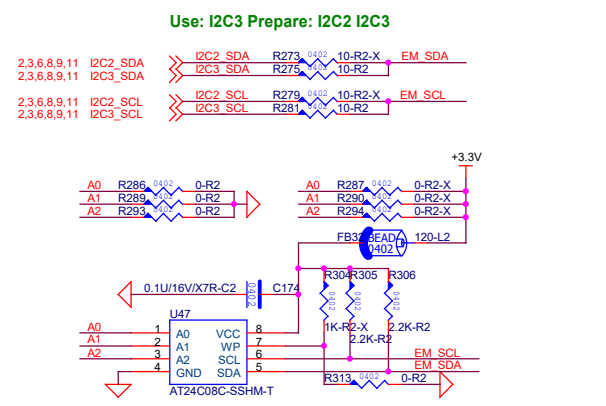

LVDS

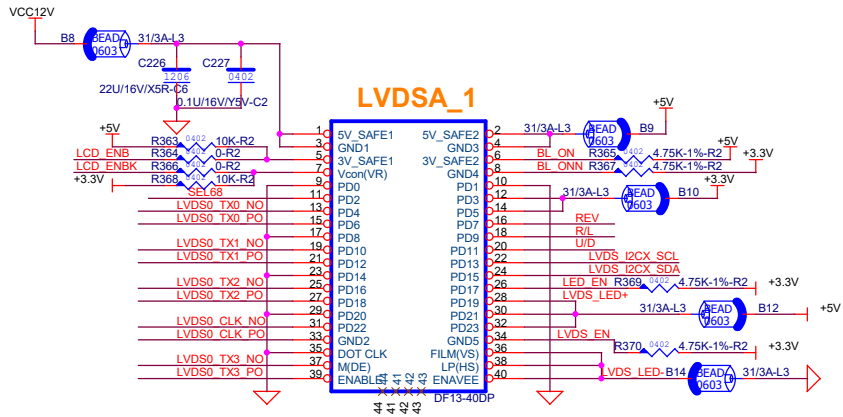

Use: I2C3 Prepare: I2C1 I2C2 I2C3

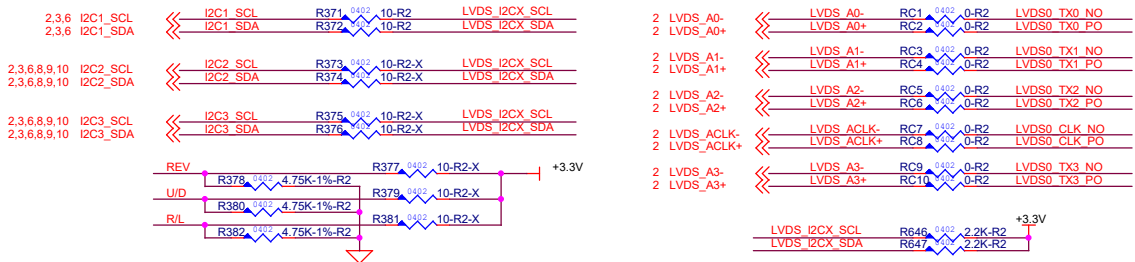

Pull H/L	SEL68
High	1-2
Low	2-3

default

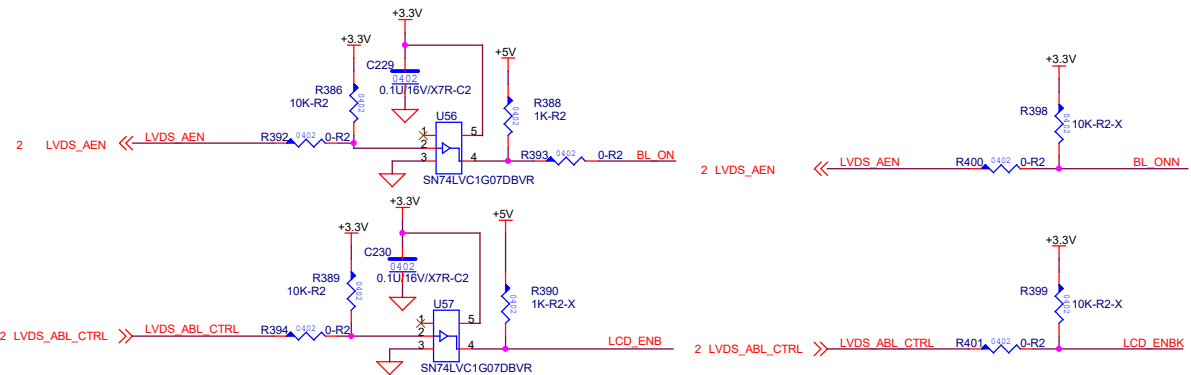
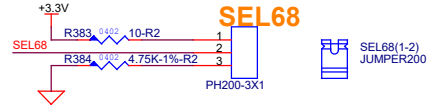

CONN

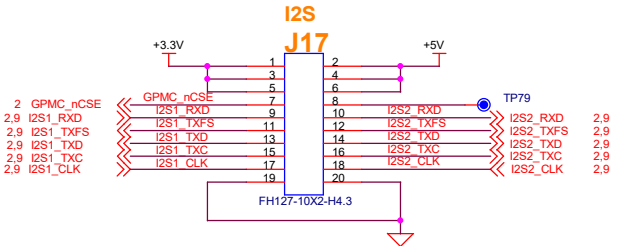
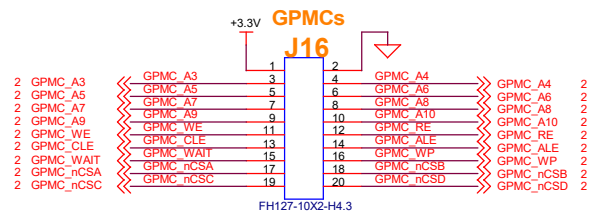
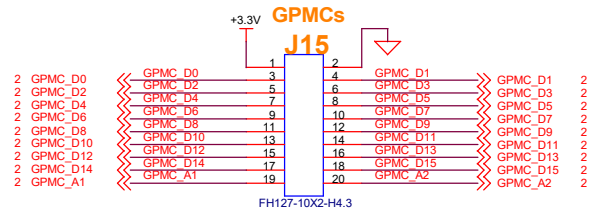

Revision History

Revision	Date	Change Description
A2	2018-08-25	Release

TechNexion		
Title		
REVISION HISTORY		
Size Custom	Document Number EDM1-FAIRY	Rev A2
Date:	Wednesday, December 09, 2020	Sheet 13 of 13